

OPERATORS INSTRUCTIONS

MODEL# DM200

TAPE DISPENSER

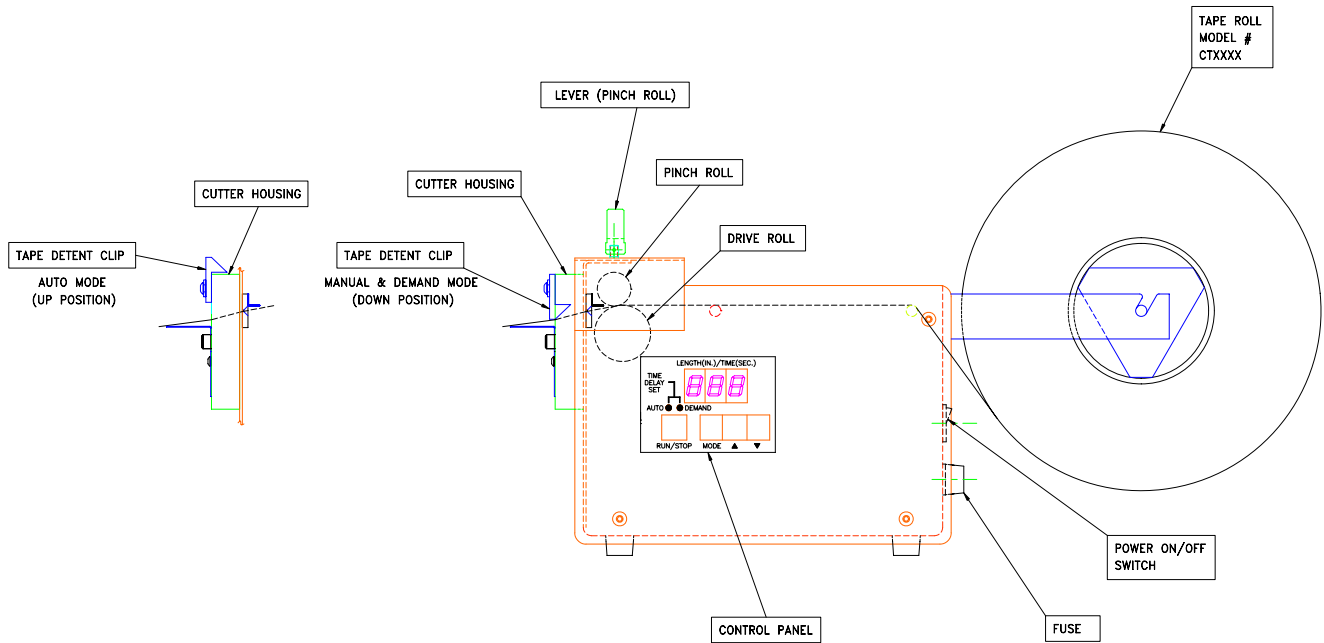

DESCRIPTION OF OPERATION

Tape Dispenser delivers medical grade, latex free, cohesive tape of pre-set lengths at pre-set time intervals in three (3) selected modes of operation.

- 1.) Manual Mode: Where operator presses the "Run/Stop" button each time a length of tape is desired.
Note: Tape Detent Clip is down.
- 2.) Demand Mode: Where a length of tape is dispensed automatically each time the operator removes it from the dispenser discharge. A pre-set time delay can be set between removal of tape length and dispensing of another if required.
Note: Tape Detent Clip is down.
- 3.) Auto Mode: Where a pre-set length of tape is dispensed continuously one after the other. A preset time delay between dispensed lengths can be set if required.
Note: Tape Detent Clip is up.

SELECTING MODE OF OPERATION

Momentarily pressing "Mode" button on panel selects mode of operation.

Two (2) red L.E.D.'s indicate mode selection.

Manual Mode - Both L.E.D.'s off.

Demand Mode - "Demand" L.E.D. on

Auto Mode - "Auto" L.E.D. on

SETTING TAPE LENGTH

The digital display normally indicates the dispensing length in inches and decimals of an inch (e.g. 4.2)

unless Time Delay set is selected. Tape length is changed by pressing the up arrow

(↑) or the down arrow (↓) button accordingly.

SETTING TIME DELAY

The digital display normally indicates tape length setting in inches. Change display to read time delay in seconds by pressing mode button until display changes and both red L.E.D.'s are on. Time delay is changed by pressing the up arrow (↑) button or the down arrow (↓) button accordingly. After desired time delay is set, momentarily press mode button to return to normal condition.

STARTING AND STOPPING TAPE DISPENSER

Plug Dispenser into 110V grounded outlet. Turn on the power switch, which is located on the back of the housing and the digital display will indicate power on. Then set mode of operation, tape length and time delay as previously described. To start dispenser; momentarily press "Run/Stop" button. Dispenser will deliver tape in the mode of operation selected. To stop dispenser, press "Run/Stop" button until L.E.D. is off then release.

NOTE: MODE OF OPERATION, TAPE LENGTH OR TIME DELAY SETTINGS CANNOT BE CHANGED UNLESS DISPENSER IS IN A STOPPED POSITION.

LOADING TAPE

Mount tape roll on Tape Roll Holder (triangular hub) with tape unwinding from the bottom of the roll. Place pinch (nip) roll release lever in "down" position lifting the pinch (nip) roll from the drive roll. Thread the tape as illustrated between guides and rolls and out through the cutter housing. Pull tape straight and place roller release lever in "up" (run) position .

NOTE: THE COATED SIDE OF THE TAPE SHOULD FACE UP. THE PAPER SIDE OF THE TAPE SHOULD FACE DOWN.

TAPE DETENT CLIP

Normally in down position, to hold tape length in discharge position. Clip should be in up position when operating in "Auto Mode".

DM200 WITH EMBOSsing FEATURE (MODEL# DM200EM)

The DM200 can also emboss characters (max.3) onto the dispensed band of cohesive tape.

Embossing requires that the pinch (nip) roll assembly contain the embossing feature. The operation of Model# DM200EM is the same as described above.

A.J. PANNERI ENTERPRISES, INC. 2727 BROADWAY CHEEKTOWAGA, NY 14227

PH: (716) 896-3585

FAX: (716) 896-3586

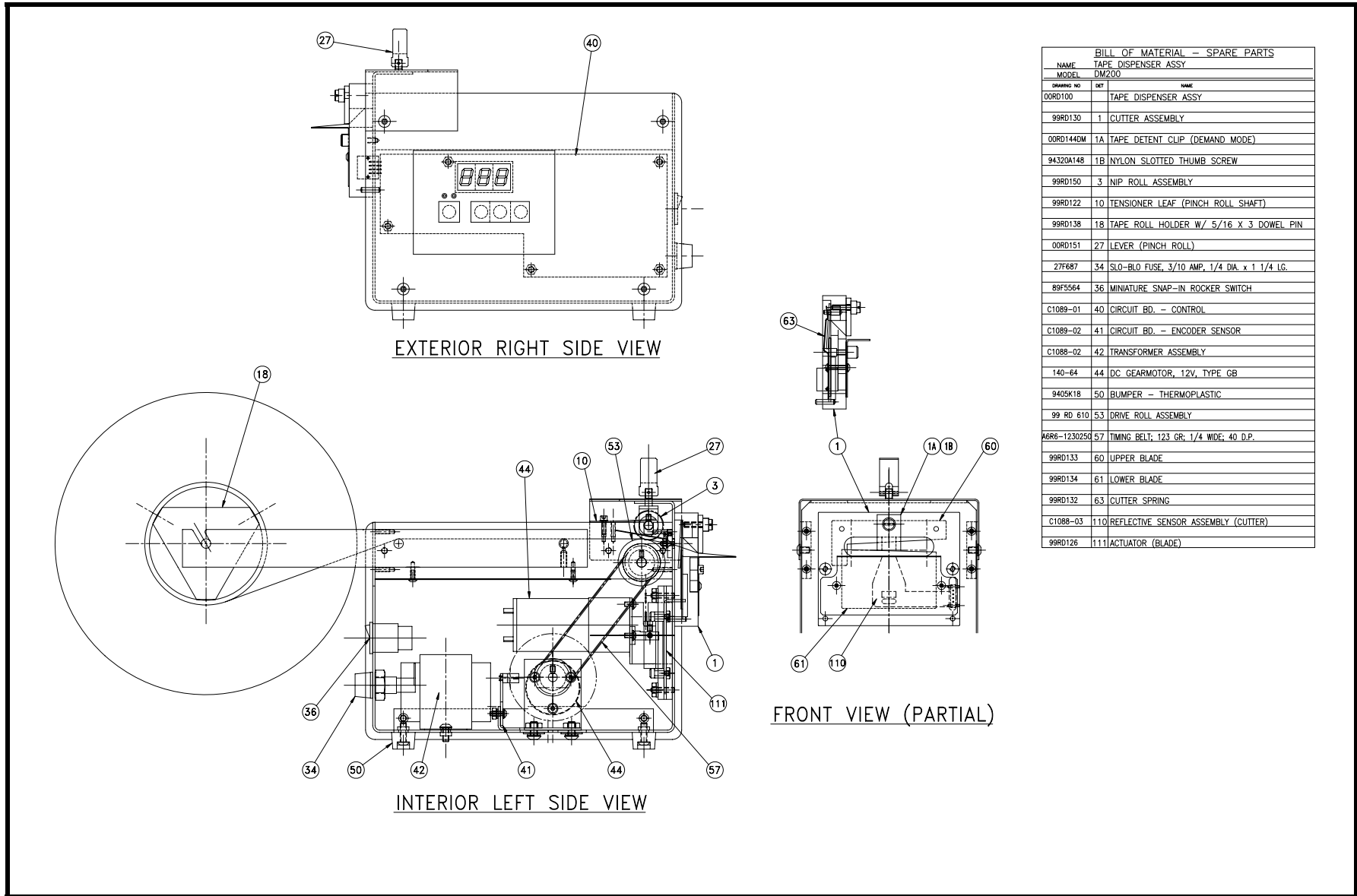

EFFECTIVE DATE 1/22/04 NOTE: EMBOSHING FEATURE MAY BE ADDED TO DM200 BY USE OF EMBOSHING NIP ROLL ASSEMBLY.

DRAWING #: 00RD100SP RECOMMENDED SPARE PARTS FOR MODEL #: DM200

SPARE PARTS ORDER FORM

A.J. PANNERI ENTERPRISES, INC.
 2727 BROADWAY AVE.
 CHEEKTOWAGA, N.Y. 14227
 PH: (716)-896-3585 FAX: (716)-896-3586

RECOMMENDED SPARE PARTS FOR DISPENSER – MODEL# DM200
REFER TO DRAWING# 00RD100 SP DATED 1/22/04

FROM:(CUSTOMER NAME) _____ PURCHASE ORDER# _____

DATE: _____

CUSTOMER CONTACT NAME: _____ CUSTOMER

PHONE/FAX: _____

PLEASE CALL FOR QUOTE

ITEM#	PART#	DET#	DESCRIPTION	ORDER QTY
1	99RD130	1	CUTTER ASSEMBLY	
2	00RD144DM	1A	TAPE DETENT CLIP (DEMAND MODE)	
3	94320A148	1B	#6-32X1/2 NYLON THUMB SCREW SLOTTED	
4	99RD150-1	3	NIP ROLL ASSEMBLY	
5	99RD122	10	TENSIONER LEAF SPRING	
6	99RD138	18	TAPE ROLL HOLDER WITH PIN	
7	00RD151	27	LEVER (PINCH ROLL)	
8	27F687	34	FUSE	
9	89F5564	36	ROCKER SWITCH	
10	C1089-01	40	CENTRAL CONTROL BOARD	
11	C1089-02	41	ENCODER WHEEL SENSOR	
12	C1088-03	110	REFLECTIVE SENSOR	
12	C1088-02	42	TRANSFORMER	
14	140-64	44	MOTOR (NOTE: DRIVE MOTOR AND CUTTER MOTOR ARE SAME)	
15	9405K18	50	BUMPER	
16	99RD610	53	DRIVE ROLLER ASSEMBLY	
17	A6R6-1230250	57	TIMING BELT	
18	99RD133	60	UPPER BLADE ONLY	
19	99RD134	61	LOWER BLADE ONLY	
20	99RD132	63	SPRING FOR CUTTER	
21	99RD126	111	BLADE ACTUATOR	

FORM EFFECTIVE DATE 1/22/04

LIMITED WARRANTY

ANY PARTS OF THE MACHINERY OR EQUIPMENT MANUFACTURED BY A.J. PANNERI ENTERPRISES, INC. WHICH WHEN OWNED BY THE ORIGINAL BUYER, UNDER NORMAL OPERATION OR SERVICE, PROVE DEFECTIVE IN MATERIAL OR WORKMANSHIP AS DETERMINED BY AN INSPECTION AUTHORIZED BY A.J. PANNERI ENTERPRISES, INC., WILL BE REPLACED FREE OF CHARGE DURING THE PERIOD OF NINETY (90) DAYS FROM THE DATE OF ORIGINAL SHIPMENT FROM THE FACILITIES OF A.J. PANNERI ENTERPRISES, INC. IN NO EVENT SHALL A.J. PANNERI ENTERPRISES, INC. BE LIABLE FOR LOSSES BASED UPON DOWN-TIME, OVERHEAD, LOST LABOR, DAMAGE TO SPOILAGE, MACHINERY, LOST PRODUCTION OR PROFITS, OR CONSEQUENTIAL DAMAGES OF ANY KIND, INCLUDING ANY GOVERNMENT RESTRICTIONS, ARISING OUT OF OR IN CONNECTION IN THIS TRANSACTION. THE FOREGOING EXPRESSED WARRANTY ON THIS AND ALL PRECEDING PAGES ARE EXCLUSIVE AND ARE IN LIEU OF ALL OTHER WARRANTIES, ORAL OR IMPLIED, INCLUDING WARRANTY OF MERCHANTABILITY AND WARRANTY OF FITNESS FOR A PARTICULAR PURPOSE. THIS WARRANTY WILL BE NULL AND VOID SHOULD THE MACHINERY BE IN OPERATION WITH PARTS, OR ROLLS OF COHESIVE TAPE OTHER THAN THOSE APPROVED, AND SUPPLIED BY A.J. PANNERI ENTERPRISES, INC. SHOULD REPAIRS BE REQUIRED, CUSTOMER AGREES TO SHIP THE MACHINERY TO A.J. PANNERI ENTERPRISES, INC., 2727 BROADWAY AVE., CHEEKTOWAGA, NY 14227. CUSTOMER AGREES TO BE RESPONSIBLE FOR ALL SHIPMENT CHARGES, AND DUTY CHARGES, AND TAXES, AND ANY OTHER CHARGES ASSOCIATED WITH THE SHIPMENT TO AND FROM A.J. PANNERI ENTERPRISES, INC. PER THE ABOVE ADDRESS.